

ANG - 2200

Acoustic Noise Generator User Manual



Research Electronics International, LLC

Revision 2.1

© COPYRIGHT RESEARCH ELECTRONICS INTERNATIONAL

REI would like to thank you for purchasing the ANG-2200 acoustic noise generator. The ANG-2200 is designed to help defend against listening devices that depend on acoustic energy being transferred through structural elements of your immediate environment (such as windows, walls, ceilings, ductwork, or plumbing). The combination of the ANG-2200, proper transducer and speaker installation, and an educated operator will contribute to a strong perimeter of protection.

NOTE: The ANG-2200 does not offer protection from recording or transmitting devices located within the perimeter; the ANG-2200 only protects against structure-bound audio leakage. REI recommends a thorough countermeasures sweep accompanied by a physical search to be performed before the installation of the ANG-2200 system and periodic sweeps thereafter to ensure the integrity of the protected environment.

REI products are designed and intended for legal commercial applications; however, because laws and regulations vary from state to state and country to country, it is the sole responsibility of the purchaser and user/operator to check and comply with all applicable laws and regulations for the possession and operation of this equipment before and after making a purchase.

Information contained in this manual, including product operation and specifications, is subject to change without notice. Any product or brand names contained in this manual are used only for identification purposes and are trademarks or registered trademarks of their respective holders.

This manual contains proprietary information intended solely for use with the ANG-2200 Acoustic Noise Generator. The overall effectiveness of this product, and of any surveillance countermeasure, is dependent on the threat level and the user's ability to properly utilize the appropriate equipment.

REI offers the world's largest commercially available Technical Security training facility. Training courses include classroom instruction and hands-on exercises where students perform sweep exercises in "live" environments utilizing target-rich project rooms. The progressive course curriculum is designed for the beginner or the seasoned Technical Security Technician.

Regularly scheduled courses are taught monthly; visit REI's website (www.reiusa.net) or contact REI (sales@reiusa.net) for training dates.

OWNER'S RECORD

Please record the ANG-2200 serial number and refer to it whenever you contact your dealer or Research Electronics International concerning this product. Note: Removal or alteration of the serial number automatically voids all warranties of this product.

SERIAL NUMBER(S): _____



Research Electronics International, LLC

455 Security Drive, Cookeville, TN 38506 U.S.A.

(800) 824-3190 (US Only) • +1 931-537-6032

www.reiusa.net

Table of Contents

Introduction.....	4
<i>Product Front</i>	<i>4</i>
<i>Product Back.....</i>	<i>5</i>
<i>Acoustic Eavesdropping.....</i>	<i>5</i>
<i>True Random Noise</i>	<i>5</i>
<i>Voice Masking</i>	<i>6</i>
<i>Operation</i>	<i>6</i>
<i>Counter-surveillance</i>	<i>6</i>
Transducer Installation	7
<i>Quantity Required.....</i>	<i>7</i>
<i>Mounting Instructions</i>	<i>7</i>
Glass, Metal, Drywall.....	7
Wood	8
Speaker Installation	9
<i>Quantity Required.....</i>	<i>9</i>
<i>Mounting.....</i>	<i>9</i>
System Setup	10
<i>Connections.....</i>	<i>11</i>
Transducers	11
OMNI MASKING SPEAKERS.....	12
<i>Wiring.....</i>	<i>13</i>
Tuning and Testing	13
<i>General Guidance for Settings.....</i>	<i>14</i>
<i>Calibration Methods</i>	<i>14</i>
METHOD #1 (Low Tech).....	15
METHOD #2 (High Tech).....	15
Specifications.....	16
Precautions	16
Appendix A: Audio Noise Masking Countermeasures and Voice Spectrum Analysis	17

<i>Background</i>	17
<i>Voice Band Energy Spectrum</i>	19
<i>White Noise and Pink Noise</i>	21
<i>Applying Noise to Perimeter Structure</i>	22
<i>REI Audio Spectrum Analysis Software</i>	22
Making a Reference Measurement	23
Analyzing and Adjusting the Noise Levels.....	25
<i>Conclusion</i>	27
Appendix B: Accessories	28
<i>Rack Mount System</i>	28
<i>OMS-2000</i>	28
<i>TRN-420</i>	29
<i>ASA-2000 (ALL-2000 included)</i>	29
<i>CMA-100</i>	30

Introduction

Product Front

The ANG-2200 front contains controls and indicators outlined below:

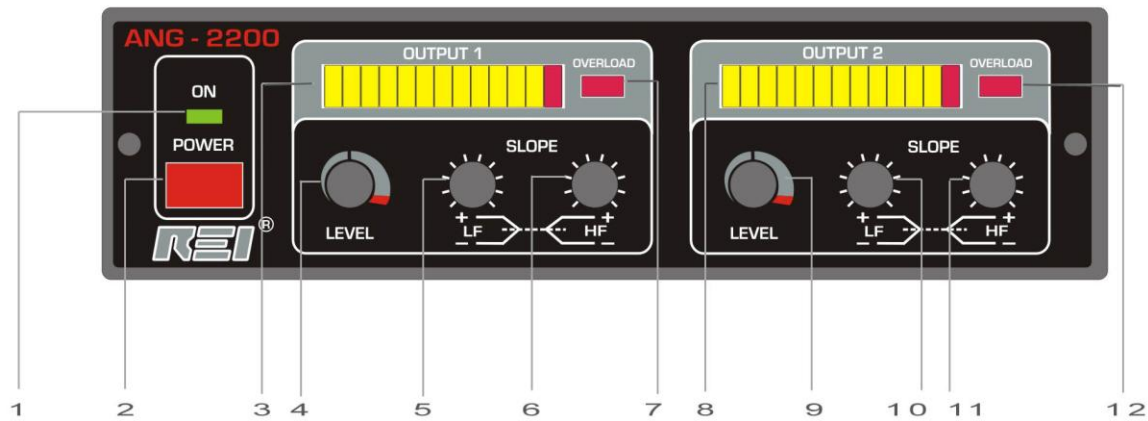

1. On Indicator
2. Power Switch
3. Level Indicator– Output 1 (Last Red Display Indicates Voltage Clipping)
4. Level Control – Output 1
5. Low-Frequency Control – Output 1
6. High-Frequency Control – Output 1
7. Current Overload Indicator – Output 1
8. Level Indicator– Output 2 (Last Red Display Indicates Voltage Clipping)
9. Level Control – Output 2
10. Low-Frequency Control – Output 2
11. High-Frequency Control – Output 2
12. Current Overload Indicator – Output 2

Product Back

The ANG-2200 back contains a power-in port and two output ports with spring clips for wire insertion.

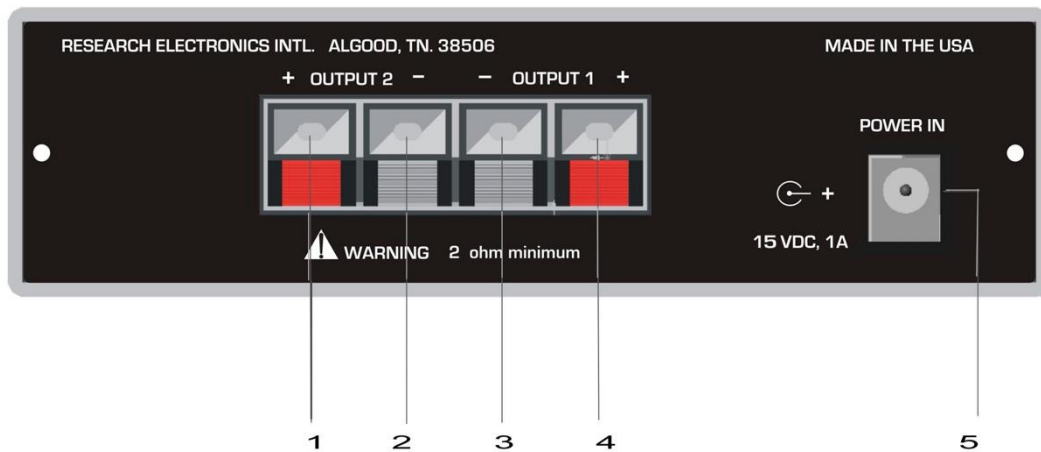

1. Positive Terminal – Output 2
2. Negative Terminal – Output 2
3. Negative Terminal – Output 1
4. Positive Terminal – Output 1
5. DC Power In – 15VDC @ 1A

Acoustic Eavesdropping

Sound vibrates surfaces such as walls, glass, and doors. A contact microphone can pick up these vibrations and transmit the information along wires or modulate it onto radio waves to be received by an unwanted listener outside the room. Laser and microwave beams reflected off these surfaces are modulated with the information and pose the same threat.

Vibrations caused by talking in a room can be transferred along air ducts, plumbing, walls, ceilings, etc. These vibrations can be intercepted and monitored by persons several floors or rooms away. This means that even though a room has been cleared of eavesdropping devices, the voice information from within that room may still be vulnerable.

The ANG-2200 system sets up a perimeter of masking noise around a room that creates a sound barrier to disrupt voice leakage. The TRN-420 transducers are designed to inject masking noise onto the room surfaces, while the OMS-2000 speakers are used to provide protection in open-air spaces, such as in closets, above ceiling tile, and in crawl spaces. This method provides a much greater masking noise envelope while producing less obtrusive noise in a room than a loudspeaker.

True Random Noise

The ANG-2200 contains two separate random noise generators. There are several products in a host of markets that use noise generators, but most use pseudo-random noise. Pseudo-random noise is generated by a mathematical formula or a pre-calculated list of values and is, in most cases, predictable. This predictability allows a sophisticated eavesdropper to correlate on this predicted noise and extract

the room's information. True random noise is naturally generated and completely unpredictable, eliminating this threat. The ANG-2200 uses true random noise.

Voice Masking

The human voice produces many frequencies when producing speech. The frequencies and their strengths are dependent on the individual and the sound he or she is making. The spoken word typically produces frequencies in the range of 100Hz to 6000Hz. Intelligible speech resides in the range of 300Hz to 3000Hz. This means that though the voice has lower and higher frequencies, the ability to understand the differences in sounds in order to create speech consists of a smaller frequency range. The ANG-2200 shapes its noise spectrum to allow for more energy within the intelligible frequency band. This shape allows for greater efficiency, better protection, and a lower obtrusive noise level.

Operation

The ANG-2200 uses a combination of transducers and speakers placed strategically throughout a target area to create a blanket of masking noise that covers private conversations from eavesdropping. The transducers come with 3M™ VHB™ adhesive rounds and small screws for mounting to a variety of surfaces, such as walls, windows, ductwork, plumbing, etc. When transducers are mounted to surfaces, the surface's material can change the shape of the ANG-2200's frequency spectrum, altering the effectiveness of the noise. The LF and HF slope controls are used to equalize the noise back to the correct shape that is required to mask intelligible speech. The two separate outputs allow the user to tailor the noise for separate surface materials, allowing greater flexibility and increased protection. See p. 13 for further information.

Counter-surveillance

Counter-surveillance is a continual challenge for security. The security individual must constantly be on guard for new techniques and technologies. Only through routine education and state-of-the-art tools can security feel confident about the job that they perform.

For more information concerning audio noise masking, please see Appendix A, "Audio Noise Masking Countermeasures and Voice Spectrum Analysis," included in the back of the manual.

Note: Devices, which are planted in close proximity to the target speaker's voice, may not be masked by the ANG-2200 because it is designed to protect the perimeter of the target area. A sweep and physical search are still recommended on a regular basis.

Transducer Installation

The ideal transducer installation would be accomplished during construction or remodeling, where sensitive points in the structure can be protected with transducers built into the building's structure. If this is not possible, the transducers can be placed directly onto wall surfaces. If visual appearance is a problem, the transducers should be disguised or covered accordingly.

Quantity Required

Determine the quantity of TRN-420 transducers needed using the guidelines below:

Walls – One transducer placed every eight linear feet, centered between floor and ceiling. Mount on or within six inches of a stud.

Floor and Ceiling – One transducer centered on every 64 square feet. (Use the OMS-2000 speaker for drop ceilings.)

Windows – One transducer placed on every major frame of glass within six inches of the corner.

Doors – One transducer placed adjacent to the center hinge on the doorframe.

Note: Shielded Screen Rooms are shielded against R.F. devices transmitting out of the room, but not necessarily against acoustic leakage. During the construction or remodeling of a screen room, the transducers can be mounted on the frame members, and acoustic insulation and a decorative panel can be installed on the inside wall surface. This will help isolate the noise generated from the room as well as decrease the acoustic leakage out of the room.

Mounting Instructions

The ANG-2200 makes use of a combination of transducers and speakers to protect the room from structure-bound leaked audio. The transducers are designed to be attached to various surfaces via either 3M™ VHB™ adhesives or small screws. Keep in mind that different materials transmit sound with various levels of efficiency. Consult p. 13 and p. 27 for testing instructions.

GLASS, METAL, DRYWALL

- 1) Unscrew the endcap from the transducer
- 2) Using the included 3M™ VHB™ adhesive, peel off one side and attach to the outside of the endcap of the transducer
- 3) Remove the 2nd side of the adhesive label and *firmly* attach it to the surface (glass, metal, or drywall)
- 4) Allow to sit for 24 hours

- 5) Attach the transducer by twisting it onto the endcap

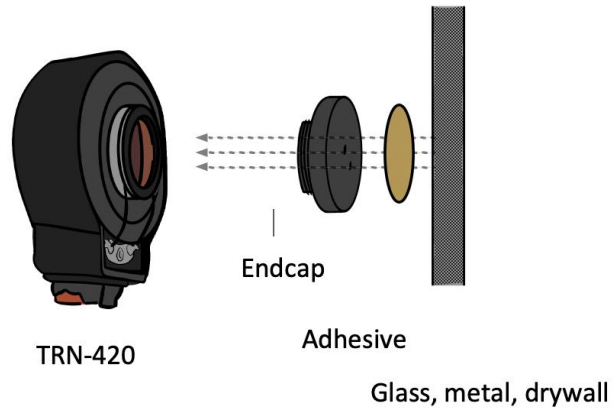

WOOD

- 1) Unscrew the endcap from the transducer
- 2) Use the two screws (included) to attach directly to wood. (If the wood is less than $\frac{3}{4}$ " thick, assess what is behind the wood to avoid hitting electrical or plumbing equipment)
- 3) Attach the transducer by twisting it onto the endcap, and use it as soon as desired

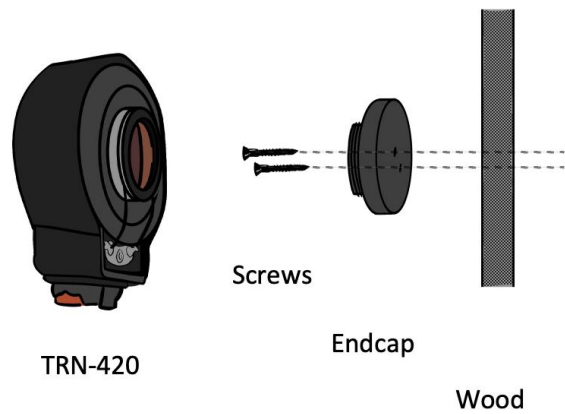

Speaker Installation

Omni Masking Speakers should be placed above ceiling tile, in storage rooms, crawlspaces, or other open-air spaces that are inside or adjacent to the target area and do not have transducers installed on the adjacent walls.

Quantity Required

Determine the number of speakers needed by the guidelines below:

- **Drop/Tiled Ceiling** — One Omni Masking Speaker centered on every 81 square feet.
- **Closets/Crawl Spaces** — One Omni Masking Speaker suspended half the height of the room, centered on every 81 square feet.

Mounting

Omni Masking Speakers are usually hung by the cable. The environment in which it is placed is the determining factor of its height positioning.

- **Drop Ceiling** — Hang the speaker one to two feet above the ceiling tile.



- **Closets/Crawl Spaces** — Place the speaker centered in the space halfway between the floor and ceiling. (illustration below)

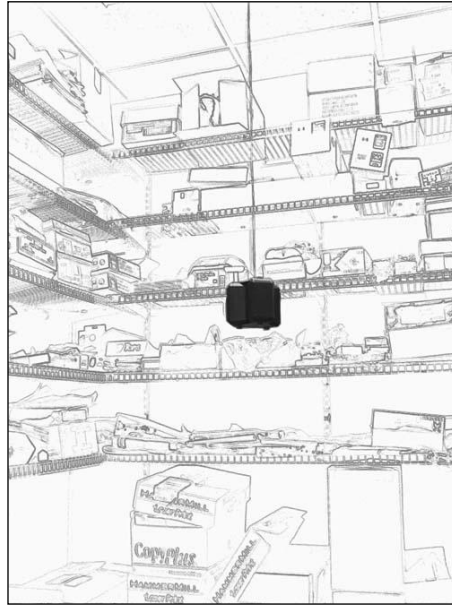

System Setup

The ANG-2200 protects against the problem of acoustic leakage by injecting masking noise onto the surface perimeter of a target area. The diversity of the perimeter (walls, windows, floors, ceilings, etc.) creates a challenge for controlling levels and the frequency spectrum of the masking noise. REI addressed this challenge by providing two independent outputs with separate frequency control. Two outputs allow the user to group similar perimeter surfaces together for level and frequency control. In large areas, more than one ANG-2200 should be employed.

When diagramming a room for acoustic protection, follow these guidelines for proper system operation:

- Group solid cement/concrete walls and floors on the same output.
- Group windows and OMS-2000 speakers on the same output when conserving outputs.
- *Do not mix OMS-2000 speakers in series with transducers.* The impedances are different.

Attn: Damage to the ANG-2200 may occur if improperly wired. The minimum total load is 2 ohms. When a load less than 2 ohms is connected and the volume is increased, the Overload Light will turn on, indicating a current overload.



Connections

When planning for room protection, keep in mind that the ANG-2200 has *two* output ports on the back. The illustrations (below) for transducer and speaker arrangements only show one port per illustration.

TRANSDUCERS

The three power combinations for transducers are illustrated below. Use “Full Power” transducers for solid or cement walls, floors, and ceilings. Use “1/2 Power” transducers for typical drywall or less dense surfaces. Use “1/2 Power” transducers for large panes of glass and “1/3 Power” transducers for small panes of glass. It is possible to combine “powers”, but the output volume of each transducer should be verified.

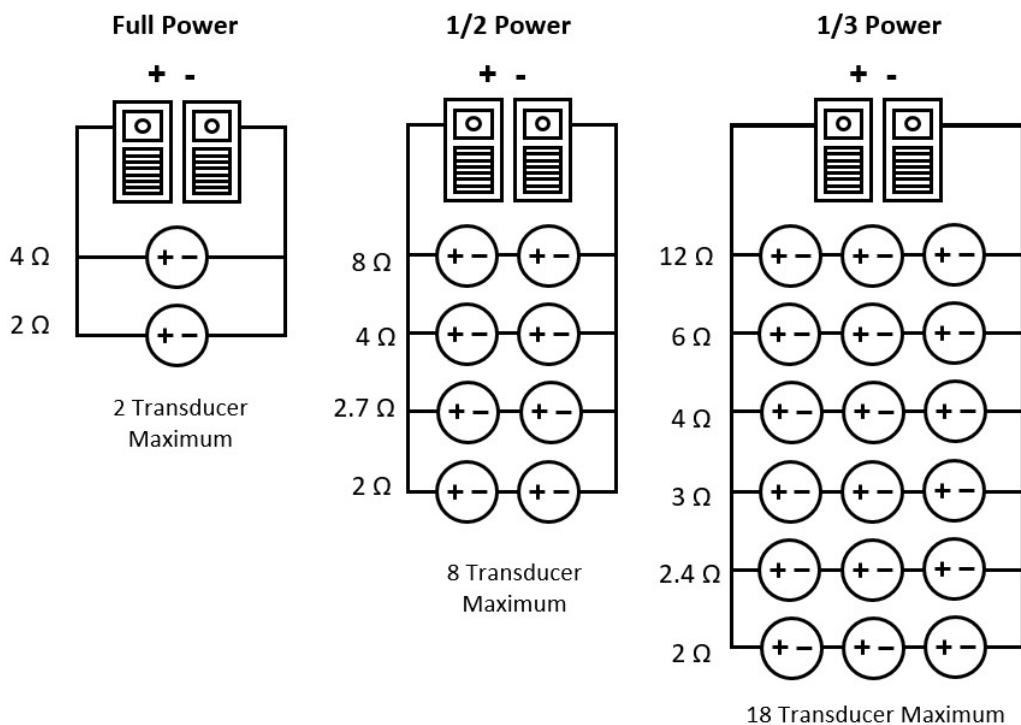

OMNI MASKING SPEAKERS

Three power combinations for the OMS-2000 speakers are illustrated below. Use “Full Power” for large closets and large crawl spaces. Use “1/2 Power” for small crawl spaces, closets, and ceilings with a large distance between the tile and the ceiling. Use “1/3 Power” for very small areas and ceilings with very little space between the tile and the top of the ceiling. Similar to the transducers, “powers” can be combined, but the output volume should be verified.

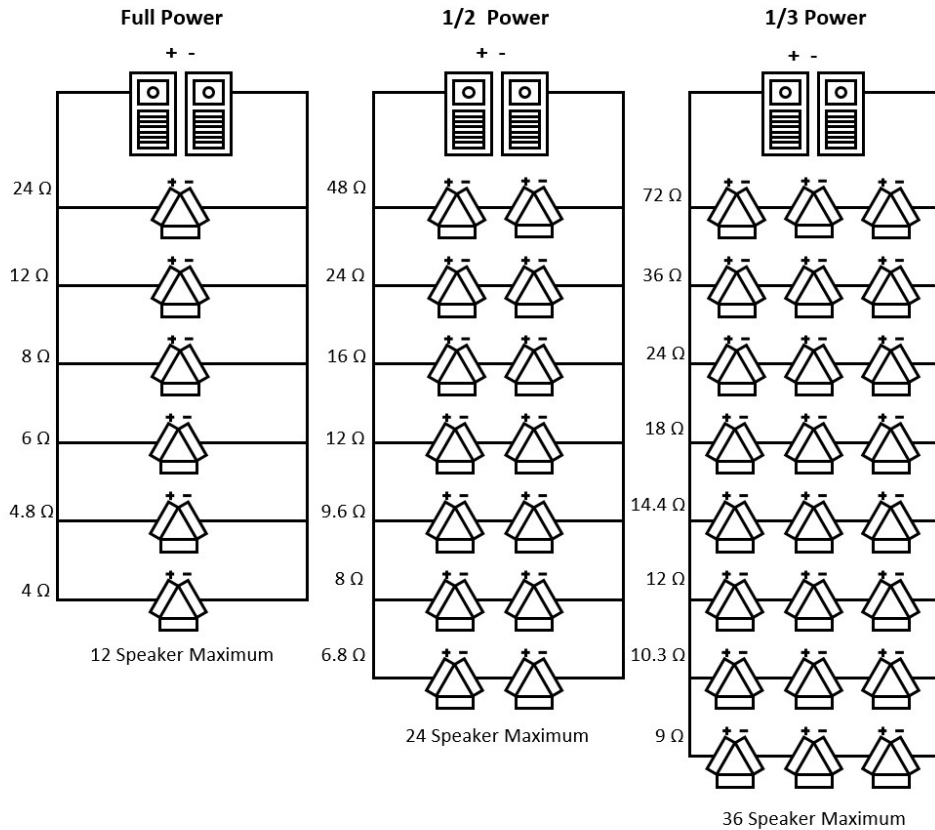

Note: Speakers can be added until 2 ohms is reached. Control of this level and frequency may become difficult due to the speaker’s location. The user should use their technical experience when connecting the speakers.

Wiring

Do not power on the ANG-2200 until wiring the transducers (as recommended in this manual) is completed.

Route the wiring so that it cannot be pinched, severed, tripped over, or damaged in any way. Insert the bare wires into the spring clips by depressing the tabs. Both the ANG-2200 units and the transducers make use of these spring clips.

For lengths of less than 60 feet, use 20-gauge “zip cord” wire. When using 20 AWG speaker wire for long wire runs, the output volume may be diminished. For example, 81’ of 20 AWG wire will result in 3 dB of attenuation. Consider verifying that the volume at the furthest transducer/speaker is sufficient before use. (Use the conductor that is silver or has markings on the insulator as the negative wire.)

Attn: Each generator output is designed to be separate and isolated. Do not cross output wiring or allow any wiring to be connected to the building’s metal or earth ground.

Tuning and Testing

Tuning the system to the particular room after installation is an important step in securing the perimeter without generating an excess amount of audible masking noise. Two methods can be utilized when tuning and verifying the system. Method #1 (Low Tech) uses the hearing abilities of the user to secure the system setup. Method #2 (High Tech) relies on software to interpret the noise and set the system's levels. REI provides the equipment that can be used for both methods. The ALP-2000 acoustic leakage probe, the CMA-100 Countermeasures Amp5, and the ASA-2000 are all products used in the methods. Method #2 (High Tech) assures the greatest protection.

When calibrating the system, the user should understand the frequency content of the noise and the idea that different surfaces and structural elements affect the content (See the Introduction section and Appendix A of the manual). Adjusting the Low- and High-frequency controls of the ANG-2200 allows the masking noise to be tailored for a particular surface. There are general rule-of-thumb settings for the frequency controls and level that are useful as starting points for calibrating the system.

General Guidance for Settings

*These settings are based upon lab tests by Research Electronics International. Because each specific site is unique, REI cannot guarantee these levels will be correct for each location. These settings should only be used as starting points for calibration methods described in the next section.

Frequency Control



Table 1

Surface	LF Slope Control	HF Slope Control
Walls	7 to 8	5
Floors/Ceiling	7	5
Glass/Windows	5 to 6	5 to 6
Speakers	9	5 to 6

Output Level



Table 2

Surface	Normal Level	½ Level	1/3 Level
Walls	4 or more	6 or more	N/A
Floors/Ceiling	4 or more	6 or more	N/A
Glass/Windows	N/A	4 or more	4 or more
Speakers	5 or more	5 or more	7 or more

Note: The Red LED (10th) indicates an excessive level. Avoid operation where the Red LED stays on continuously.

Calibration Methods

The goal is to find the most vulnerable surface areas and adjust the ANG-2200 controls to provide enough masking noise to conceal acoustic leakage at these points. The weakest areas are usually the surfaces of the wall or window furthest away from a transducer or the ceiling at the maximum distance away from a speaker. These areas are potentially the greatest threat, and if they are protected, the rest of the perimeter of the room is protected.

METHOD #1 (LOW TECH)

Needs: Contact Microphone, Audio Amplifier, and a Known Sound Source (Radio or high-quality recording of conversation)

The sound source should be situated in the room in a location where conversations will be conducted and set to a volume representative of normal room conversation. Use the contact microphone and audio amplifier to check the perimeter of the room for acoustic leakage points. After marking the areas of greatest concern, turn on the ANG-2200 at a low level and check each of the marked areas for leakage. If the sound source can be heard and understood, then increase the level and repeat the test. Repeat these steps until the sound source cannot be heard. Frequency controls are more difficult to adjust using this method and can be increased or decreased according to the experience and judgment of the user.

METHOD #2 (HIGH TECH)

Needs: Contact Microphone, Computer loaded with the ASA-2000 software, and a Known Sound Source (Radio or high-quality recording of conversation)

The sound source should be situated in the room in a location where conversations will be conducted and set to a volume representative of normal room conversation. Use the contact microphone connected to the input of the computer's soundcard to make a reference measurement of acoustic leakage from the room. The ASA-2000 software is used to take the reference and comparison measurements. Turn on the ANG-2200 and adjust the level and frequency controls until the noise measurement is a predetermined amount greater than the leakage reference measurement. 20dB is the recommended amount to ensure effective masking. See Appendix A (p.17) for more information.

Specifications

Acoustic Noise Generator (ANG-2200)

Size:	1.6 in x 5.5 in x 8 in (4.1 cm x 14 cm x 20.3 cm)
Weight:	1.3 lbs. (590 g)
Output Max:	12 Vp-p @ 6 Ω
Min. Load:	2 Ω
Frequency:	125 Hz – 4 kHz
Power:	15VDC @ 1A

Transducer (TRN-420)

Dimensions:	2.8 x 2.3 x 1.2 in
Impedance:	4 Ω
Power handling (RMS):	20 W
Frequency range:	20Hz – 20 kHz
Weight:	3.3 oz

Omni Speaker (OMS-2000)

Size:	5 in x 5.75 in (12.7 cm x 14.6 cm)
Weight:	2 lbs. (907 g)
Impedance:	24 Ω

Precautions

- Do not connect more than three transducers in parallel or loads that present impedance less than 2 ohms to the output
- Avoid areas with high moisture
- Do not drop
- Provide adequate ventilation around the ANG-2200
- Avoid extreme temperature exposure below -22F (-30C) or above 122F (50C)
- There are no serviceable parts inside — contact your dealer or Research Electronics International for repairs. Opening the unit will void the warranty



Appendix A: Audio Noise Masking Countermeasures and Voice Spectrum Analysis

Using audio noise to mask confidential conversations and to provide a countermeasure to eavesdropping is a useful technique that has been utilized for many years; however, it is a basic technology that is often misunderstood and improperly implemented. This article is intended to provide a good understanding of the effects of voiceband noise masking and some guidance about proper implementation.

Background

Perimeter Masking Techniques

Important principles:

- If two people can hear each other talk and there is a microphone in close proximity to the people, then the microphone can “hear” the conversation as well.
- If a single noise-generating device is placed between two people, it does not work well to mask the conversation. The main reason is the location of the noise-generating source. If the two people can talk above the noise and hear each other, then so will a covert microphone.

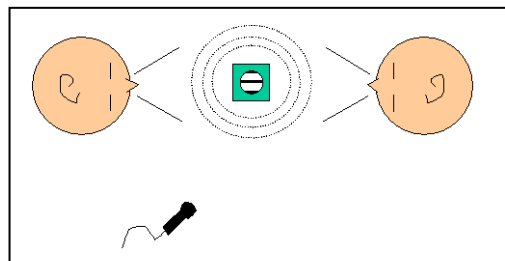

Note: Noise masking countermeasure techniques should only be considered a perimeter function.

Proper method: Design a noise-masking perimeter so that listening devices at the edge or outside of the perimeter will have difficulty acquiring intelligible audio.

Illustration: Perimeter noise-masking design for conference room (see diagram).

- Noise masking transducers placed along the walls and along the glass
Noise masking speakers within the ceiling spaces.

If the masking noise level is properly adjusted and a listening device is placed within walls or in the ceiling, then the listening device will pick up masking noise, and the potential loss of information is greatly reduced. However, if a listening device is brought into the room near the conversation area, then the perimeter noise masking system can be defeated.

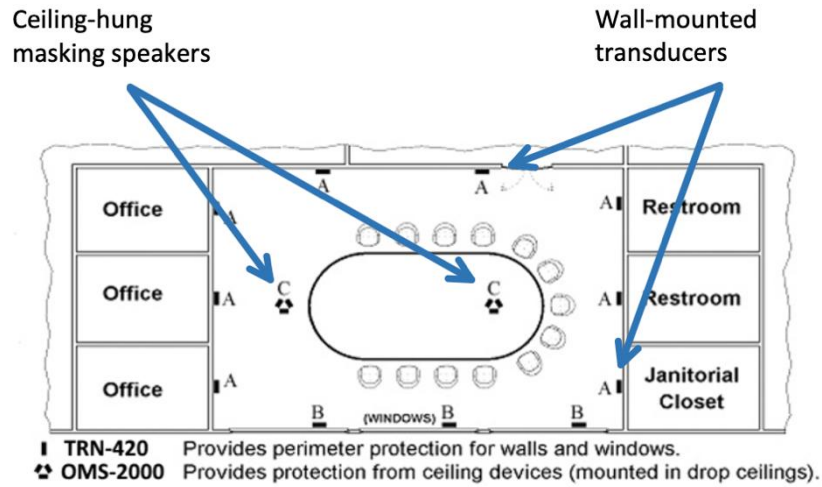

Voice Band Energy Spectrum

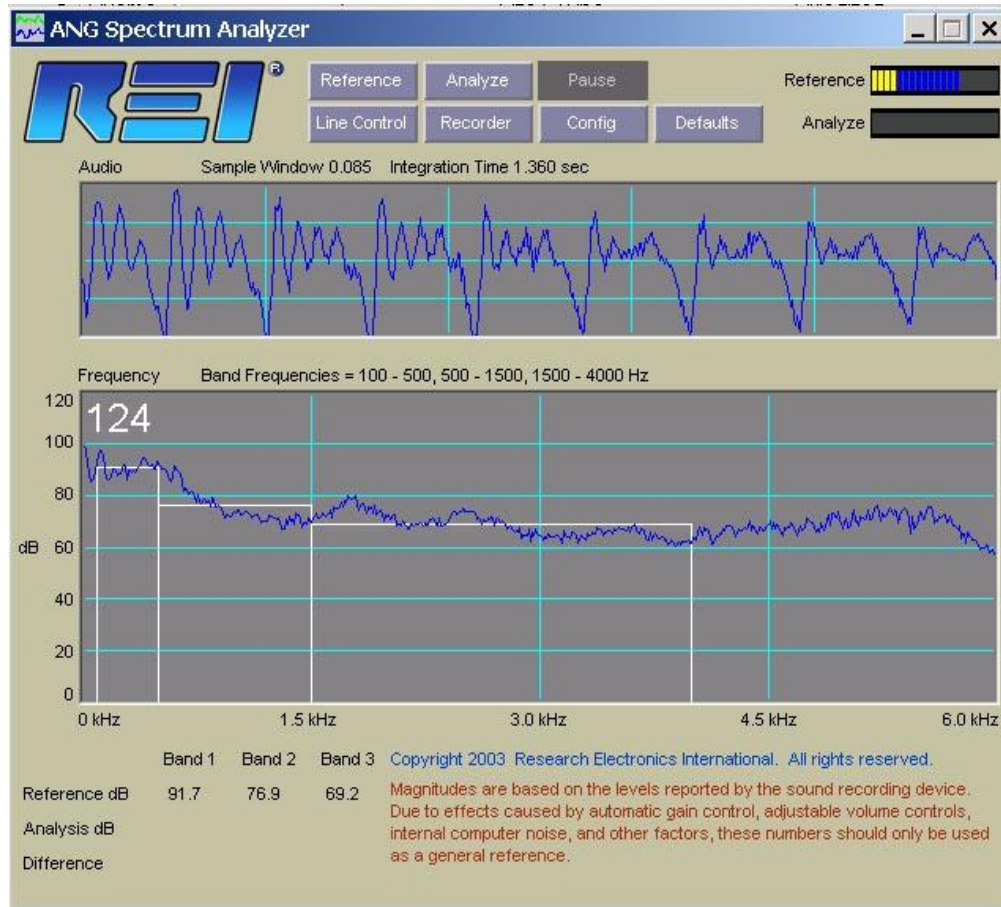

The above graphs using the ASA-2000 Audio Spectrum Analysis Software represent the frequency spectrum of the author's voice saying "Testing 1, 2, 3" in a normal speaking voice. Observe:

- Most of the energy exists at lower audio frequencies.
- There are a few obvious dominant frequencies in the lower frequency range.
- The energy in frequencies above 500Hz is not as well defined as the energy in the lower frequencies.
 - Note: The top graph shows the time domain and indicates some very periodic activity. But it is very hard to predict what portion of the speech is visible in the short 0.085-second sample window displayed.

Important noise-masking characteristics:

- Most energy from an individual's voice occurs at the primary vocal frequency (124Hz in the previous graphic).
- This resonant energy is generally created by speaking vowel sounds such as "a, e, i, o, and u". However, while vowel sounds contain a large amount of voice energy, these resonant sounds do not provide a lot of the energy associated with the intelligibility of the spoken word.

- The sounds that affect intelligibility are more dominated by consonant sounds such as T, K, P, D, B, etc., and consonant sounds occur at higher frequencies.

Therefore, the intelligibility of the spoken word is contained in the energy associated with higher-frequency consonant sounds.

Some basic audio frequency characteristics:

	Minimum Frequency	Maximum Frequency
Hi-Fidelity Music Audio	20 Hz	15 kHz
Normal Hearing	~50 Hz	~13 kHz
Telephone Audio	300 Hz	3 kHz

Note: While much of the voice band energy is below 300Hz, the telephone system basically ignores this energy. This works because most of the sound that affects the intelligibility of audio exists between 300 Hz and 3 kHz. Furthermore, this is the accepted frequency band for most voice-band communications.

One last point is that human hearing responds in a logarithmic manner. In other words, humans hear better at higher frequencies (~1500Hz to ~6000Hz) as indicated below by the “Threshold of Hearing” curve.

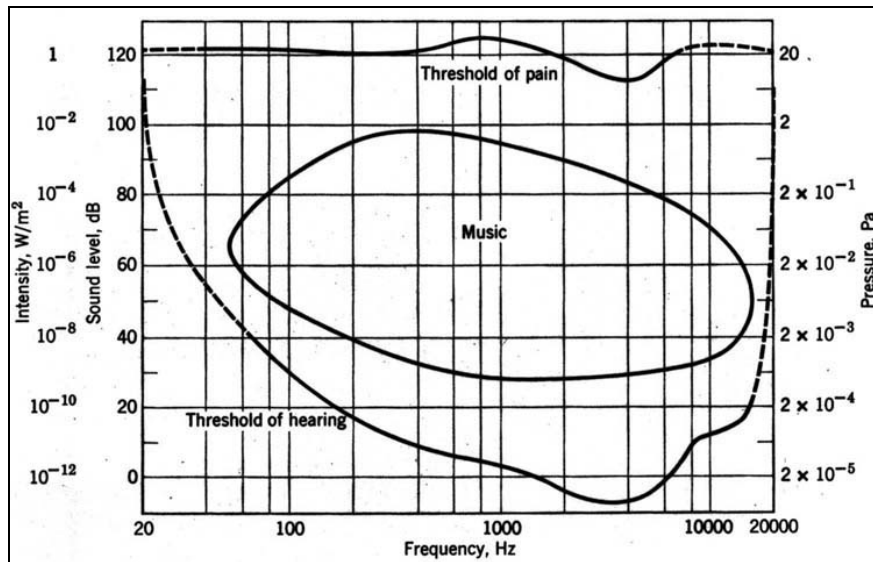

**Average Sound Intensities for Human Hearing
(Courtesy of Bell Telephone Laboratories)**

Conclusion: Much voice-band energy exists below 300Hz, *but the frequency range that should be masked most effectively is from 300Hz - 3 kHz*. This conclusion is based on the normal range of voice band energy that affects the intelligibility of conversation and the human ear’s ability to hear at those frequency ranges.

White Noise and Pink Noise

Some systems advertise White Noise, and some advertise Pink Noise — this section will address the difference.

White Noise has equal energy per frequency – the energy frequency spectrum is basically flat. Since human hearing responds in a logarithmic manner (see the previous graph), White Noise sounds to a human as if the high frequencies are loudest (the audio sounds “Brighter”).

Pink Noise has equal energy per frequency octave. The noise energy level decreases as frequency increases, or, for example, there is the same amount of energy in each of the following frequency bands:

100 — 200 Hz

200 — 400 Hz

400 — 800 Hz

800 — 1600 Hz

Pink Noise has a frequency roll-off similar to the human hearing capability and therefore sounds less bright and richer at the lower frequencies when compared to White Noise.

The question: What is the best type of noise to use as an eavesdropping countermeasure?

The focus: Defeat intelligibility of the spoken word in the surrounding perimeter (rather than simply create a pleasant sound environment). This goal generally takes more power and sound energy in the perimeter of the protected space.

Therefore, a White Noise system is more generally appropriate because energy is evenly distributed and the higher frequency components (and thus the intelligibility) of the spoken word are more greatly impacted by the energy level in a white noise system.

A more appropriate approach is a Noise Masking system in which the noise frequency spectrum is customized for the application at hand. The REI ANG-2200 system provides this capability.

Because Pink Noise sounds richer to the human ears, it is often used for noise masking applications in large office spaces where the goal is not necessarily to block the intelligibility of audio in an adjacent office, but to create a pleasant noise level such that the adjacent office conversations and general offices noises – keyboards, printers, footsteps, water fountain, typewriters, coffeepot, etc. – will not disturb the train of thought for everyone around. In this type of application, the goal is generally to provide a wide area diffuse sound field of masking noise.

Applying Noise to Perimeter Structure

As previously described, Noise Masking for Eavesdropping Countermeasures requires that the noise be injected into the surrounding structure. This can be done using transducers and speakers. One major problem is that, regardless of the frequency response of the electronically generated masking noise (whether it's White or Pink), the structure in which the noise is injected will also have a major impact on the noise frequency spectrum.

- Glass is a very stiff, brittle material, which responds well to higher-frequency signals
- Wood paneling is very flexible and will respond much better to lower-frequency noise

Therefore, regardless of the noise spectrum that is electronically generated, the noise spectrum that exists in the perimeter structure will be influenced by the physical nature of the structure.

For this reason, REI has developed a noise masking system that is adaptable to various types of structures, and a testing procedure and software to adjust the proper noise level and frequency spectrum to the specific application.

REI Audio Spectrum Analysis Software

Purpose: To measure the audio being absorbed by environmental structures and then analyze and adjust noise masking levels for an effective countermeasure.

- STEP 1: Make a reference measurement to get a baseline of the amount of noise being absorbed into the structure.
- STEP 2: Inject masking noise into the structure and use the software to measure and adjust the level for effective masking.

In this manner, the ASA-2000 software provides a useful tool for customizing the ANG-2200 settings for different environments and different building materials.

Main Display Screen:

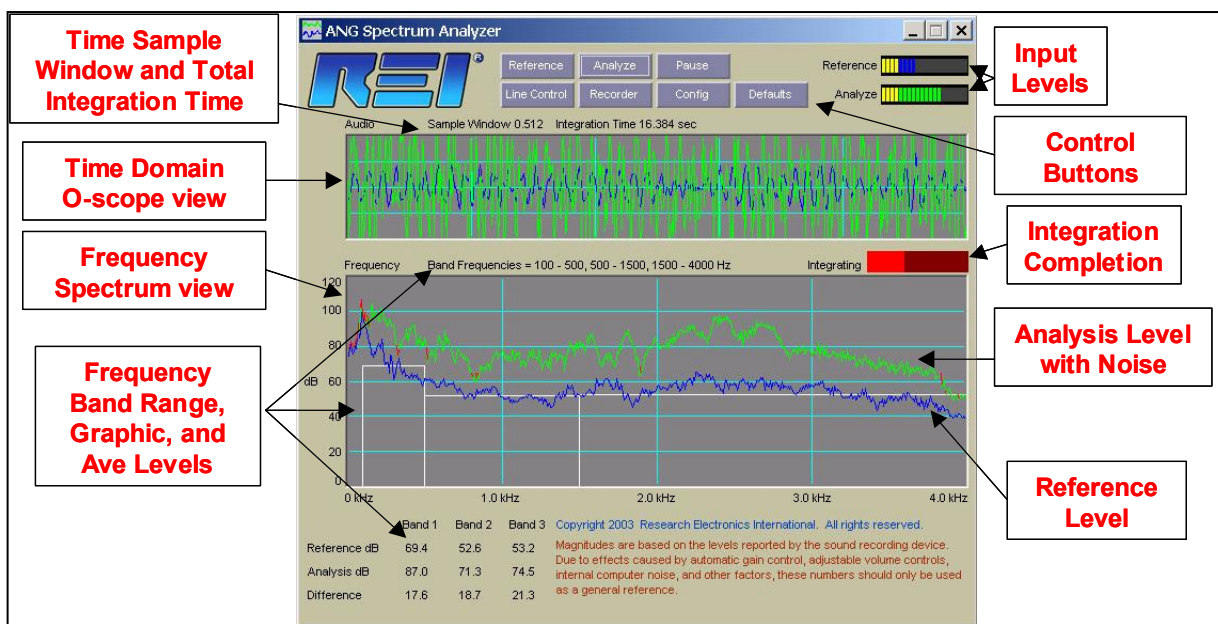

Top graph: Time-domain graph (basically an oscilloscope view of the audio). Displays the most recently sampled time window.

Bottom graph: The frequency spectrum, generated by integrating (basically averaging) from multiple sampled windows of time.

Middle, right-side bar graph (labeled “Integrating”): Indicates when the required number of windows has been sampled to produce the integrated spectrum display.

Band ranges: The software breaks the spectrum into 3 frequency bands. These bands are somewhat arbitrary but are provided to show a basic average level of masking over a desired frequency range.

Note that even after the integration is complete, the software continuously measures and integrates new sampled time windows. The total integration time is also indicated in the menu. The sampling and integration parameters can be adjusted as described later in this document.

During the Reference Measure integration time (STEP 1), the software automatically normalizes the input data from the Acoustic Leakage Probe (REI’s contact microphone). This normalization is performed mainly for graphing purposes.

Note on magnitudes (dB levels): Magnitudes shown in the display are not accurate in an absolute sense. They are based on the data reported by the sound recording device in the computer (the sound card). Due to the effects of differing sound cards, automatic gain control settings, volume control settings, internal computer noise, and other factors, the ASA-2000 software should not be used for making accurate sound level measurements; however, the software provides an excellent tool for measuring relative sound levels associated with measuring audio leakage in a structure, with and without injected noise masking.

MAKING A REFERENCE MEASUREMENT

1. Plug the Acoustic Leakage Probe (ALL-900) into the proper 3.5mm jack on the computer.
2. Place the Probe on the desired surface to be tested. Use either the suction cups or push pins provided with the Probe. If the microphone is held in place by hand, the measure has error and noise introduced due to the movement of the hand. (Note: the ASA-2000 software can also accept audio from an external source such as the REI Counter Measures Amplifier (CMA). In this case, the CMA contact microphone is plugged into the CMA, and the CMA line-out is plugged into the computer’s ‘Line Input.’ This configuration provides slightly better performance because of the quality in the CMA amplifier circuits and the CMA voice band filter.)
3. Start the ASA-2000 software and click on “Line Control”. If the probe is plugged directly into the computer, select Microphone (check ‘Select’). If an alternate audio source is used, such as the CMA as previously described, then select Line-Input. The input volume level should be set relatively low.
4. Close the Line Control window and click “Reference” to turn on the audio spectrum analysis function and begin displaying input from the probe. To ensure that the probe is working properly, make a known noise by clapping, whistling, singing, etc., and visually check that the

software is responding as expected. Note: The reference measurement can be restarted at any time, or the display can be paused by pressing the “Reference” or “Pause” buttons.

5. Click “Config” to review the Sampling Parameters and other configuration parameters. “Threshold” indicates the desired level of masking. (The example above used a 10dB masking level.) The software uses this number to graphically indicate the areas of the frequency spectrum where the desired masking level is achieved. There are several other parameters that can be adjusted using this menu. These settings can be saved for future analysis.
6. Click “Recorder” to make sample recordings of measured audio. The default Windows audio recorder can be used to record WAV file examples of noise audio, both before and after noise masking (Reference vs. Analysis).

Line Control.

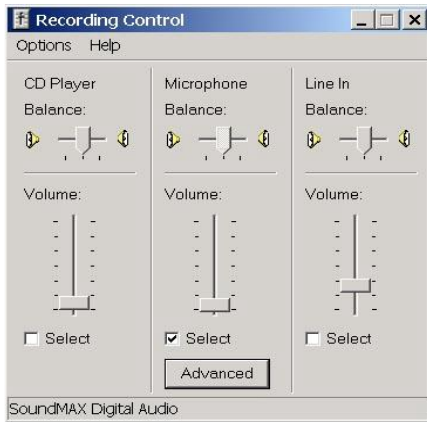

Sound Recorder



Configuration Control.

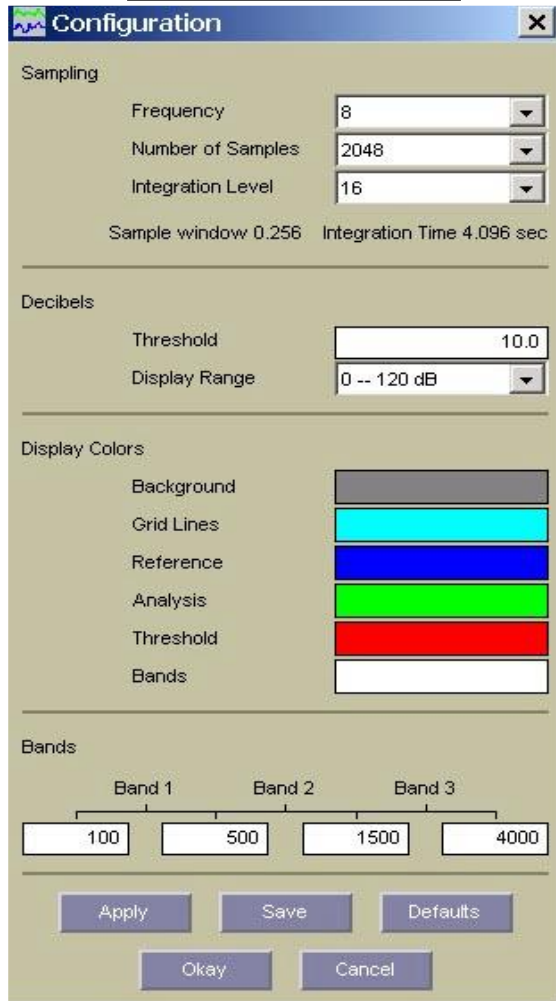

- When a satisfactory Reference measurement has been recorded, click “Pause” to freeze the internal settings and prepare to analyze the noise masking capability. The following graphic is a good example of a reference measurement. (Note: this example used music as a reference source, indicated by the many dominant frequencies in the spectrum. Human voice would not have the dominant higher frequency components displayed here.)

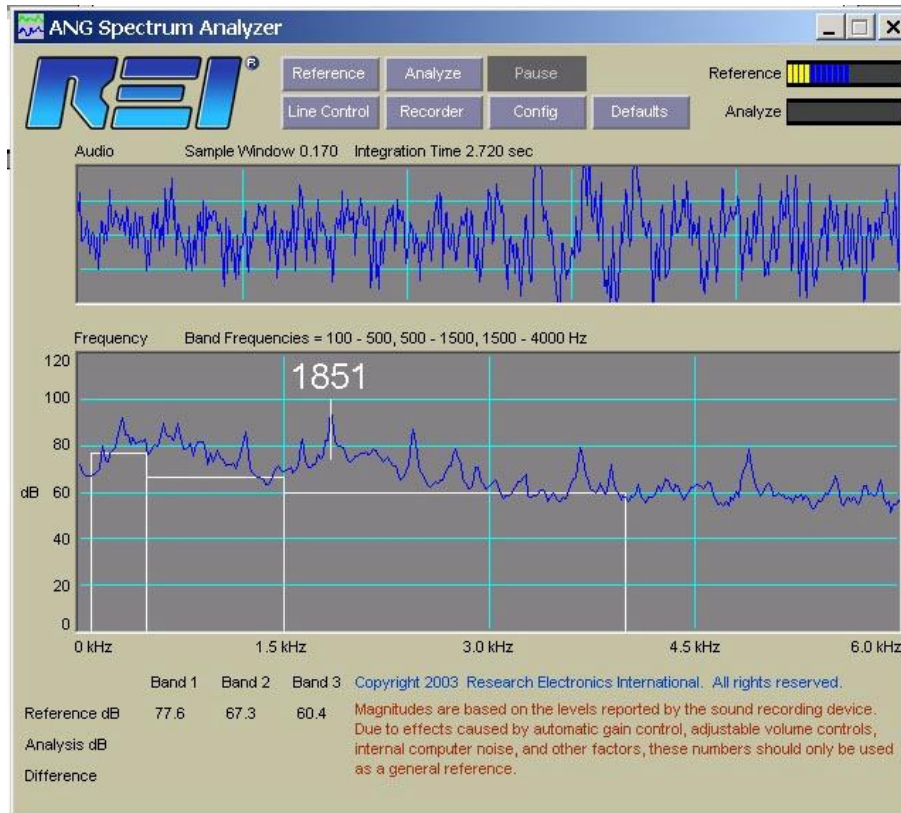

ANALYZING AND ADJUSTING THE NOISE LEVELS

After the Reference measurement has been taken, turn on the masking noise source (ANG-2200).

Press the Analyze button to begin the Analysis process.

When the integration process is completed, adjust the ANG Level control to increase or decrease the overall noise level, and use the Slope adjustments to adjust the noise to the frequency response.

The following two screenshots depict analysis and adjustment scenarios. The first graphic shows a noise level that is very weak at the low end (Band 1) of the frequency spectrum. The second graphic shows the noise masking level after the slope of the noise frequency spectrum has been adjusted. Even in the second graphic, the masking level in Band 1 appears weak in some areas, but the overall average of the noise masking level is still well above the desired level. The desired masking level of this example was set to a 20dB masking level. This 20dB masking level was accomplished using the output’s slope controls on the ANG-2200.

Band 1

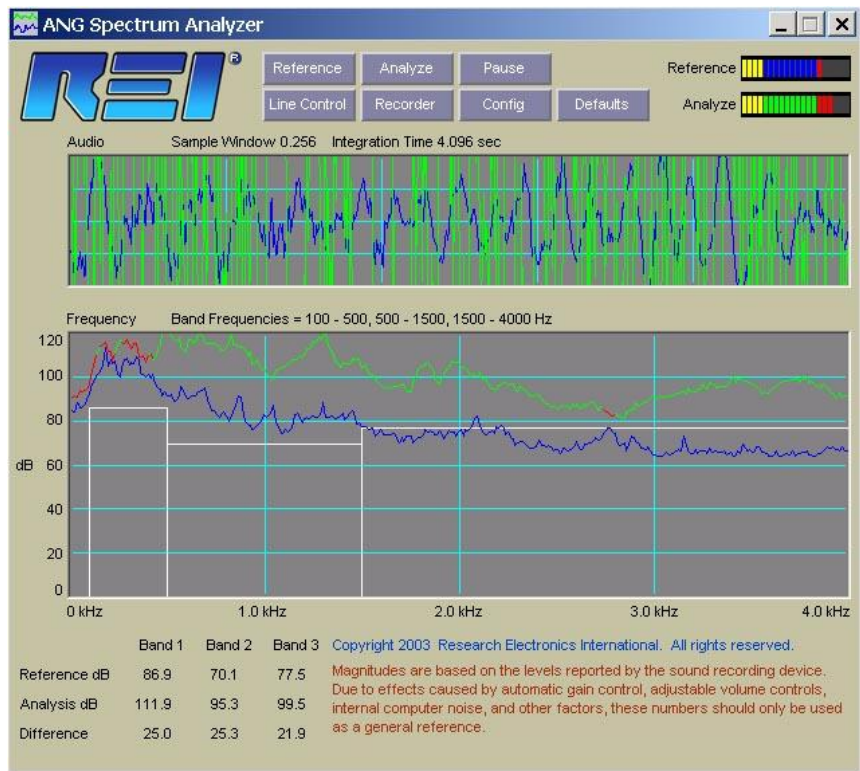
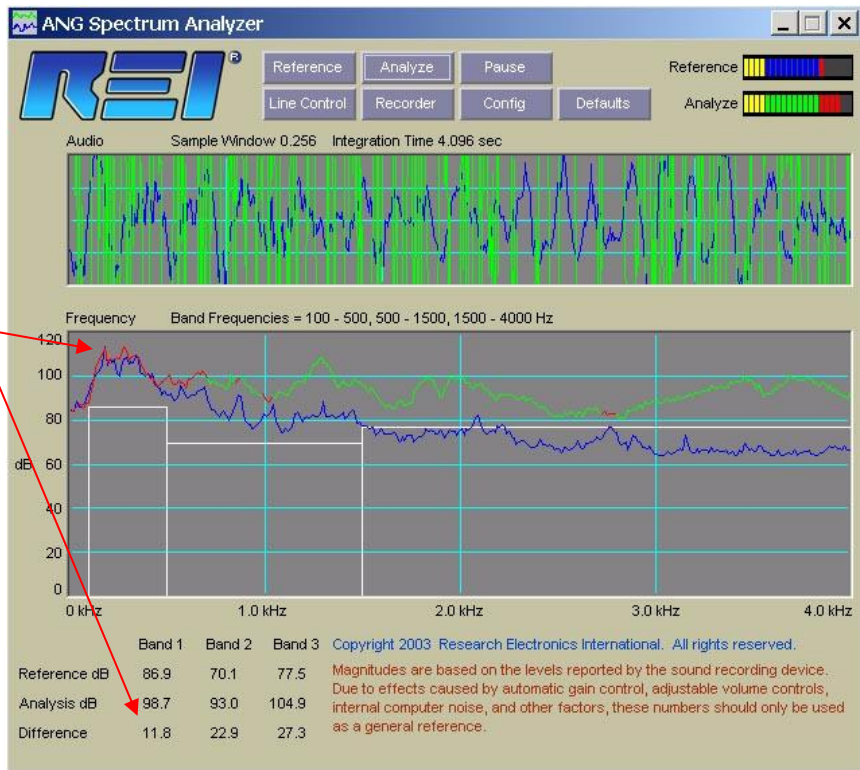

Conclusion

The ASA-2000 software provides a useful method for properly setting up, testing, and calibrating a noise masking system. Furthermore, ASA-2000 can help reduce any confusion over White Noise, Pink Noise, and blanket noise masking. Consider the following:

- Different structural surfaces have different responses to audio. Some surfaces will respond more to high frequencies, and some will respond to low frequencies, and many surfaces will have characteristic resonant frequencies.
- Many surfaces in a building will have inherent ambient noise from the building itself. This ambient noise may be due to structure-borne audio sources such as traffic noise, machinery, people walking, elevators, printing machines, etc.
- When measuring noise surfaces, it is easy to introduce error. These errors may be due to many factors such as the placement of the Acoustic Leakage Probe, the method of holding the contact microphone, and the inherent noise in the sound card system used to measure the noise spectrum.

The ASA-2000 system is based on the comparison of before and after noise masking of all the frequencies in the voice spectrum. This approach ignores the exact definition of White or Pink Noise and provides acoustic noise masking that is designed and calibrated for the specific masking application at hand.

Appendix B: Accessories

Rack Mount System

Rack Mount System available for secure centralized control of multiple Acoustic Noise Generators.



OMS-2000

Omni Masking Speaker - The Omni directional Speaker is used with the ANG-3000 to project acoustic noise into drop ceiling air spaces, closets, crawl spaces, and air ducts.



TRN-420

ANG Transducer - REI's TRN-420 is a specially designed transducer used to inject acoustic noise into walls, finished ceilings, windows, plumbing, and air ducts.



ASA-2000 (ALL-2000 included)

Audio Spectrum Analyzer - The purpose of the Audio Spectrum Analysis software is to provide the capability to measure the audio being absorbed by environmental structures and then analyze and adjust the noise masking levels for an effective countermeasure without being too loud and/or disruptive. Includes the ALL-2000 contact microphone.



CMA-100

Countermeasures Amplifier - The Countermeasures Amplifier (CMA-100) is a high-gain audio amplifier. It is used in conjunction with ALA-100 (contact microphone) to identify audio leakage threats and verify proper noise masking.

